

National Auto Club Underwriters Agency (NZ) Ltd
 Freephone 0800-501 508, Fax (09) 430 7456
 Level 3, 36 Water St, Whangarei.
 PO Box 1840, Whangarei.

Please note: All the questions on this form must be clearly and fully answered otherwise the processing of this claim may be delayed until the required information is supplied. If any question does not apply to the circumstances of your claim it must be marked "NOT APPLICABLE." You must answer all relevant questions truthfully. Your failure to do so may prejudice your claim.

insured

full name _____ address _____

registered owner
 name _____ address _____

phone _____ business or occupation _____
private business

insured vehicle

make and model _____ year _____ Reg No. _____ WOF expires _____ / _____ / _____
Day Month Year

Has the vehicle been modified in any way? **Yes / No**
 If yes, give details _____

Is there any other insurance on the vehicle or its accessories? **Yes / No**
 If yes, give details _____

Give the name and address of anyone with a financial interest in the vehicle e.g. hire purchase, mortgage, etc

Pre-existing damage to vehicle? **Yes / No**
 If yes, give details _____

Indicate the damaged area on this diagram

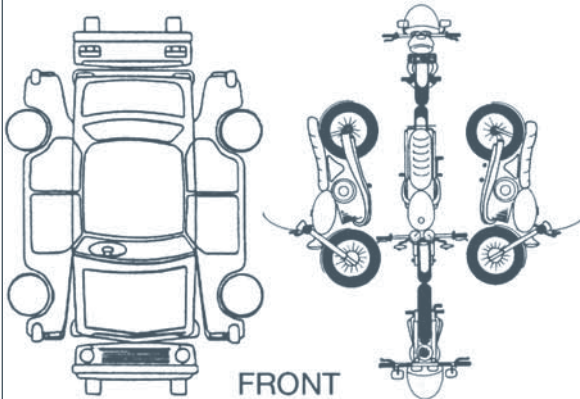

Give details of damage to the insured vehicle

Where can the vehicle be inspected? _____

Has an estimate for the costs of repairs been obtained **Yes / No** If yes, give amount: \$ _____

driver - to be completed by the driver

full name _____ address _____

date of birth _____ occupation _____

phone _____ relationship to the insured _____
private business

Do you have a current driving licence for this type of vehicle? **Yes / No** If yes: Licence Number _____ Years held _____

What type of licence do you hold? _____ Version # _____

Is your licence subject to any restrictions? **Yes / No**
 If yes, give details _____

Have you ever been convicted of any traffic or driving offence in the past five years? **Yes / No**
 If yes, give details _____

Have you ever had a motor vehicle accident previously? **Yes / No**
 If yes, give details _____

Answer the next three questions only if the driver is not the Insured

Was the vehicle being driven with the authority and permission of the Insured? **Yes / No**
 If no, give details _____

Do you own a motor vehicle of your own? **Yes / No**

If yes, who is it insured with? Company _____ Branch _____
 Make _____ Registration Number _____

Have you ever been refused motor vehicle insurance or had a policy cancelled by an insurer? **Yes / No**
 If yes, give details _____

driving conditions *to be completed by the driver* Tick the appropriate box(es) for each section

<i>weather</i>	<input type="checkbox"/> fine	<input type="checkbox"/> bright sun	<input type="checkbox"/> overcast	<input type="checkbox"/> fog	<input type="checkbox"/> light rain	<input type="checkbox"/> heavy rain
<i>road surface</i>	<input type="checkbox"/> sealed	<input type="checkbox"/> slippery	<input type="checkbox"/> metal	<input type="checkbox"/> clay	<input type="checkbox"/> good	<input type="checkbox"/> wet
<i>lighting at scene of accident</i>	<input type="checkbox"/> none	<input type="checkbox"/> poor	<input type="checkbox"/> good	<input type="checkbox"/> excellent		
<i>lighting on your vehicle</i>	<input type="checkbox"/> not on	<input type="checkbox"/> park	<input type="checkbox"/> dip	<input type="checkbox"/> full		

What was your speed • prior to the accident? _____ km/h • at impact _____ km/h

Was your vehicle on the correct side of the road? **yes ~ no** *If yes*, how far from the kerb? _____ metres
If no, where was it?

Police/Traffic Department involvement

Did a police or traffic officer attend the accident? Yes ~ No OR Were the police advised of the accident? Yes ~ No
If yes, name or number: _____ where based: _____

Had the driver consumed any intoxicating liquor or taken any drugs within 12 hours of the accident? Yes ~ No
If yes, what? _____ what quantity? _____ over what period? _____

Was a breath or blood alcohol test requested or taken after the accident? Yes ~ No
If yes, with what result? _____

Have you been advised whether any person is to be charged with any offence in respect of this accident? Yes ~ No
If yes, who? _____ what is the charge? _____

other parties important: **No liability should be admitted by you, or any offer made to compensate for damage All communications received should be forwarded to us immediately.**

Do you consider the accident to be your fault? Yes ~ No
If no, why not? _____

Did the other driver admit liability? Yes ~ No
If yes, give details _____

Name, address, phone of the **owner** of the other vehicle (or property)

Name, address, phone of the **driver** of the other vehicle

Details of the other vehicle Make _____ Model _____ Reg No. _____
 Insurer of the other vehicle Company _____ Branch _____

damage to other property *fences, clothing, poles, etc*

Description of property _____
 Name, address of owner _____
 Name of insurer (if any) Company _____ Branch _____

details of witnesses to the accident

		<i>if Yes, name</i>	<i>address</i>	<i>phone</i>
own passengers	1			
	Yes ~ No	2		
independent witnesses	1			
	Yes ~ No	2		



- The issue of this form is not an admission of liability.
- No liability is to be admitted to a third party • No repairs are to be done without the Company's permission.
- If you receive any communication in any way connected with the accident, please forward it to the company immediately



National Auto Club Underwriters Agency (NZ) Ltd
 Freephone 0800-501 508, Fax (09) 430 7456
 Level 3, 36 Water St, Whangarei.
 PO Box 1840, Whangarei.

declaration

The Insurance Claims Register Ltd (ICR), PO Box 474 Wellington, holds details of claims made after 1 February 1998 under policies issued by participating insurers. Participating insurers can check details of your claims history on the ICR.

I agree that National Auto Club Underwriters (Agency) NZ Ltd as a participating insurer may give to or obtain from ICR details of information relevant to this claim.

I hereby declare that the foregoing particulars are true to the best of my knowledge and belief, and I undertake to assist the Company to the full in dealing with this matter.

I also authorise the NATIONAL AUTO CLUB UNDERWRITERS AGENCY (N.Z) LTD to obtain any information relative to the claim from any appropriate authority e.g. Ministry of Justice, Police, medical authority, etc.

PLEASE SUPPLY A COPY OF YOURS AND YOUR SUPERVISORS DRIVER LICENCE(S)

signature of driver _____ date _____

signature of insured _____ date _____

drug/alcohol declaration *to be completed if requested*

I _____
name

of _____
address

occupation

solemnly and sincerely declare that I was a driver of a _____ reg number _____
vehicle

at the time of the incident in which the vehicle was involved, at or about _____ on _____
time date

and that in the preceding twelve hours I had consumed _____ of _____
amount type

After the accident and prior to any breath test being taken I consumed _____ of _____
quantity if nil state NIL type

I hereby authorise the NATIONAL AUTO CLUB UNDERWRITERS AGENCY (NZ) LTD to obtain the result(s) of such test(s) and I make this solemn declaration conscientiously believing the same to be true and by virtue of the Oaths and Declaration Act 1957.

Declared at _____ this _____ day of _____
Location Month Year

Signature of Driver: _____ Before me: _____
Justice of the Peace or other person authorised to take a Statutory Declaration

Note Section III of the Crimes Act 1961 makes liable to imprisonment for a term not exceeding three years every person who, on any occasion on which he is required or permitted by law to make any declaration before any person authorised by law to receive it, makes a declaration that would amount to perjury if made on oath in a judicial proceeding.